

## BS 100

---



### BS 100

- 1 Fixed louvres
- 2 Moveable louvres
- 3 Louvre grip
- 4 Walkway
- 5 Connections within the system

### Connections with other systems

CW 50

BS 100 - CN002 ... CN003



### 1 Fixed louvres

Fixed louvres in a vertical plane

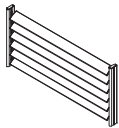

BS 100 - 002

Fixed louvres in a horizontal plane

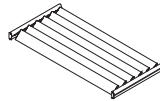

BS 100 - 005

### 2 Moveable louvres

Moveable louvres with motor drive



BS 100 - 009

### 3 Louvre grip

Fixed louvres in a vertical plane

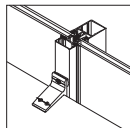

BS 100 - 010

### 4 Walkway



BS 100 - 012

### 5 Connections within the system



BS 100 - 014

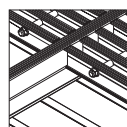

BS 100 - 015

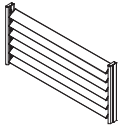

Fixed louvres in a vertical plane

General remark :

(\*) For recommendation on max. admissible sizes !  
Every typical situation and specific project has to be  
calculated / validated by an official structural engineer.

L<sub>w</sub> lamella width

h Louvre distance

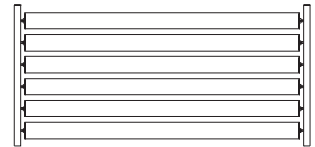

h= Depending on louvre dimension and slope.

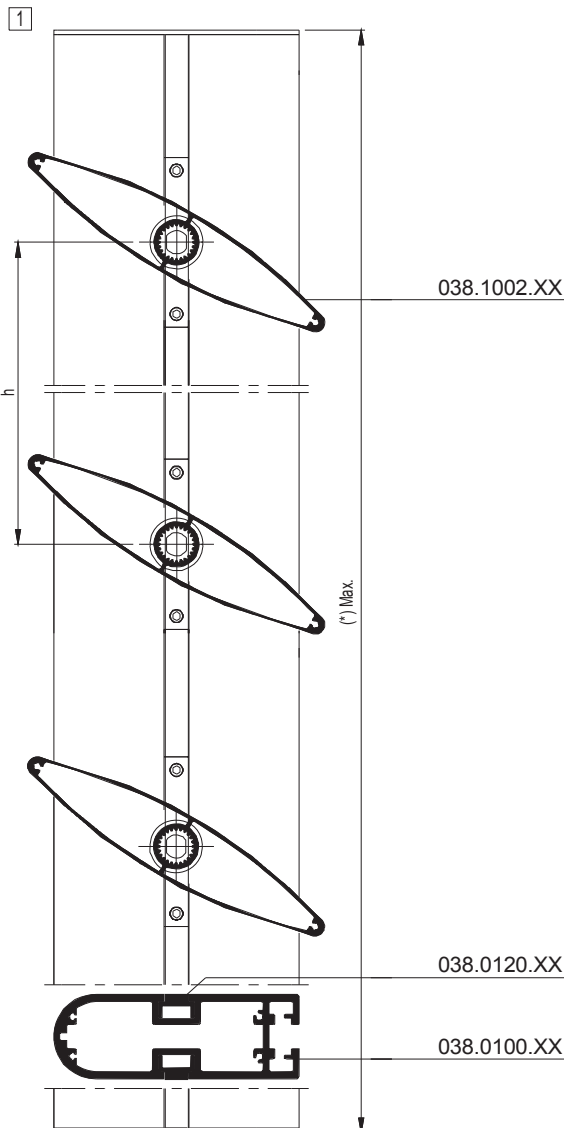

... .dxf  
... .dwg



### Louvre slope 0°

PR. NR.	L <sub>w</sub>	h		
		15°	30°	45°
038.1000.XX	120 mm	35	70	120
038.1001.XX	140 mm	40	85	140
038.1002.XX	180 mm	55	105	180
038.1003.XX	200 mm	60	120	200
038.1004.XX	250 mm	70	145	250
038.1005.XX	300 mm	85	175	300
038.1006.XX	400 mm	110	235	400

### Louvre slope 15°

PR. NR.	L <sub>w</sub>	h		
		15°	30°	45°
038.1000.XX	120 mm	65	100	145
038.1001.XX	140 mm	75	115	170
038.1002.XX	180 mm	95	145	220
038.1003.XX	200 mm	105	165	245
038.1004.XX	250 mm	130	205	305
038.1005.XX	300 mm	155	245	365
038.1006.XX	400 mm	210	325	485

### Louvre slope 30°





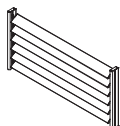

PR. NR.	L <sub>w</sub>	h		
		15°	30°	45°
038.1000.XX	120 mm	85	120	160
038.1001.XX	140 mm	100	140	185
038.1002.XX	180 mm	130	180	240
038.1003.XX	200 mm	145	200	270
038.1004.XX	250 mm	180	250	335
038.1005.XX	300 mm	220	300	405
038.1006.XX	400 mm	290	400	540

### Louvre slope 45°

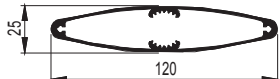
PR. NR.	L <sub>w</sub>	h		
		15°	30°	45°
038.1000.XX	120 mm	105	130	165
038.1001.XX	140 mm	125	155	195
038.1002.XX	180 mm	160	195	250
038.1003.XX	200 mm	175	220	280
038.1004.XX	250 mm	220	275	350
038.1005.XX	300 mm	265	330	420
038.1006.XX	400 mm	355	445	560

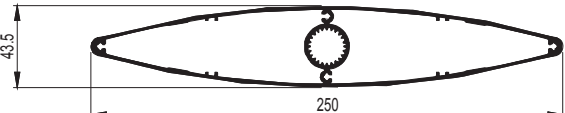

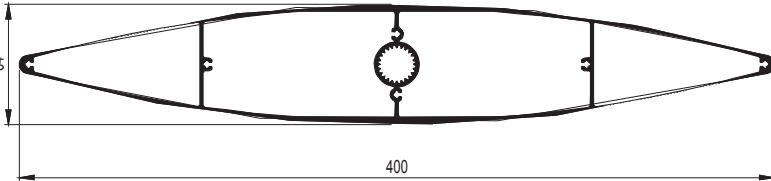
Fixed louvres in a vertical plane

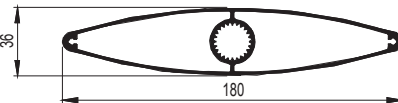
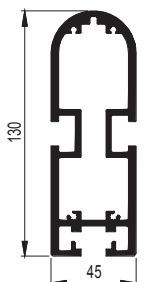
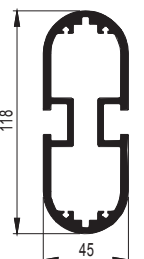
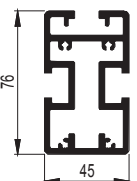
<p><b>038.1000.XX</b></p> <p><math>I_x = 4.048 \text{ cm}^4</math></p>  <p>1 BS100-001001.dxf BS100-001001.dwg</p>	<p><b>038.1001.XX</b></p> <p><math>I_x = 6.007 \text{ cm}^4</math></p>  <p>1 BS100-001007.dxf BS100-001007.dwg</p>	<p><b>038.1004.XX</b></p> <p><math>I_x = 28.005 \text{ cm}^4</math></p>  <p>1 BS100-001004.dxf BS100-001004.dwg</p>
<p><b>038.1003.XX</b></p> <p><math>I_x = 17.128 \text{ cm}^4</math></p>  <p>1 BS100-001003.dxf BS100-001003.dwg</p>	<p><b>038.1006.XX</b></p> <p><math>I_x = 120.307 \text{ cm}^4</math></p>  <p>1 BS100-001006.dxf BS100-001006.dwg</p>	
<p><b>038.1005.XX</b></p> <p><math>I_x = 44.002 \text{ cm}^4</math></p>  <p>1 BS100-001005.dxf BS100-001005.dwg</p>	<p><b>038.1002.XX</b></p> <p><math>I_x = 12.444 \text{ cm}^4</math></p>  <p>1 BS100-001002.dxf BS100-001002.dwg</p>	
<p><b>038.0100.XX</b></p> <p><math>I_x = 273.649 \text{ cm}^4</math></p>  <p>1 BS100-001001.dxf BS100-001001.dwg</p>	<p><b>038.0101.XX</b></p> <p><math>I_x = 190.887 \text{ cm}^4</math></p>  <p>1 BS100-001008.dxf BS100-001008.dwg</p>	<p><b>038.0106.XX</b></p> <p><math>I_x = 66.772 \text{ cm}^4</math></p>  <p>1 BS100-001010.dxf BS100-001010.dwg</p>

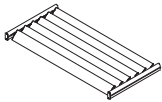

Fixed louvres in a horizontal plane

General remark :

(\*) For recommendation on max. admissible sizes !  
Every typical situation and specific project has to be calculated / validated by an official structural engineer.

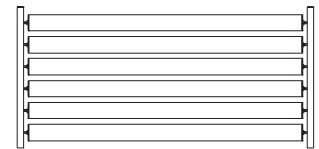
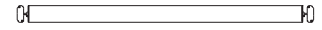

### Louvre slope 0°

PR. NR.	Lw	h		
		45°	60°	75°
038.1000.XX	120 mm	120	70	35
038.1001.XX	140 mm	140	85	40
038.1002.XX	180 mm	180	105	50
038.1003.XX	200 mm	200	115	55
038.1004.XX	250 mm	250	145	70
038.1005.XX	300 mm	300	175	85
038.1006.XX	400 mm	400	230	110

### Louvre slope 15°

PR. NR.	Lw	h		
		45°	60°	75°
038.1000.XX	120 mm	145	95	60
038.1001.XX	140 mm	170	115	70
038.1002.XX	180 mm	215	145	90
038.1003.XX	200 mm	245	160	105
038.1004.XX	250 mm	305	200	130
038.1005.XX	300 mm	365	240	155
038.1006.XX	400 mm	485	325	205

### Louvre slope 30°

PR. NR.	Lw	h		
		45°	60°	75°
038.1000.XX	120 mm	160	115	85
038.1001.XX	140 mm	185	135	100
038.1002.XX	180 mm	240	175	130
038.1003.XX	200 mm	270	195	145
038.1004.XX	250 mm	335	245	180
038.1005.XX	300 mm	405	295	220
038.1006.XX	400 mm	540	395	290

### Louvre slope 45°

PR. NR.	Lw	h		
		45°	60°	75°
038.1000.XX	120 mm	165	130	105
038.1001.XX	140 mm	195	155	125
038.1002.XX	180 mm	250	195	160
038.1003.XX	200 mm	280	220	175
038.1004.XX	250 mm	350	275	220
038.1005.XX	300 mm	420	330	265
038.1006.XX	400 mm	560	440	355

h= Depending on louvre dimension and slope.

2

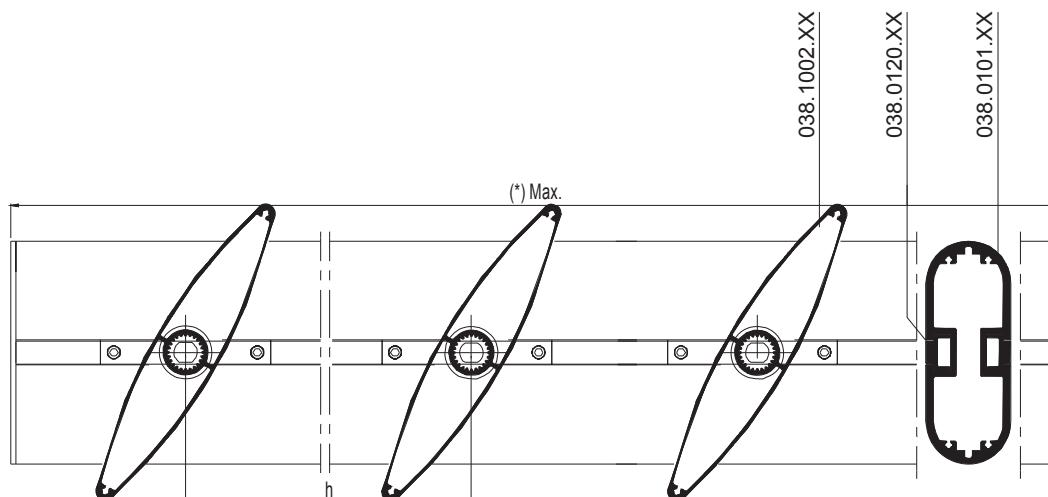

BS100-002001.dxf  
BS100-002001.dwg

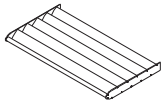

Fixed louvres in a horizontal plane

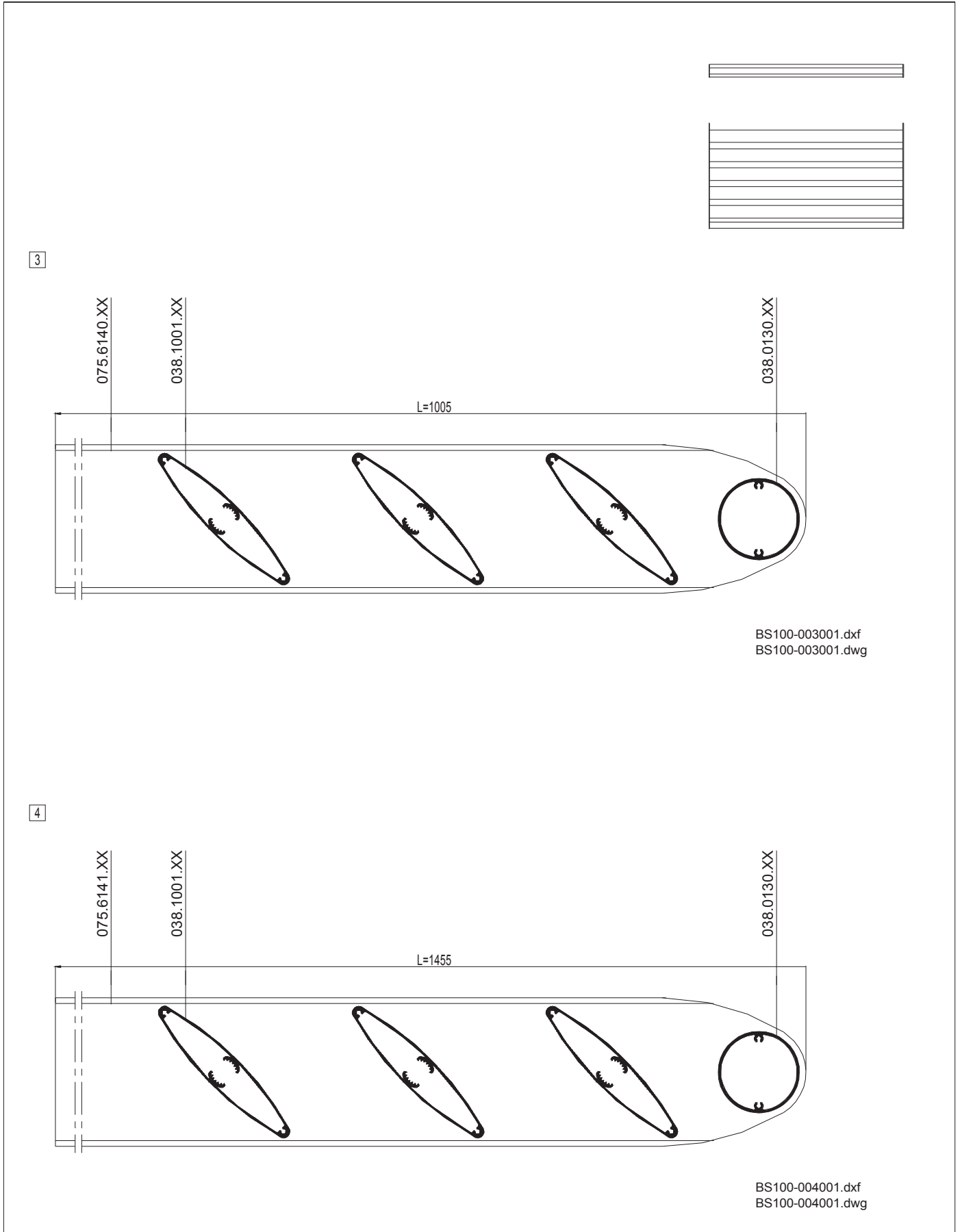

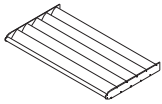

Fixed louvres in a horizontal plane

Louvre slope 45°

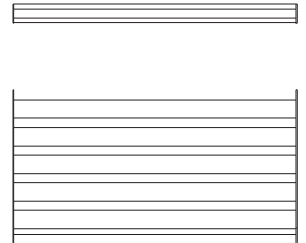

6

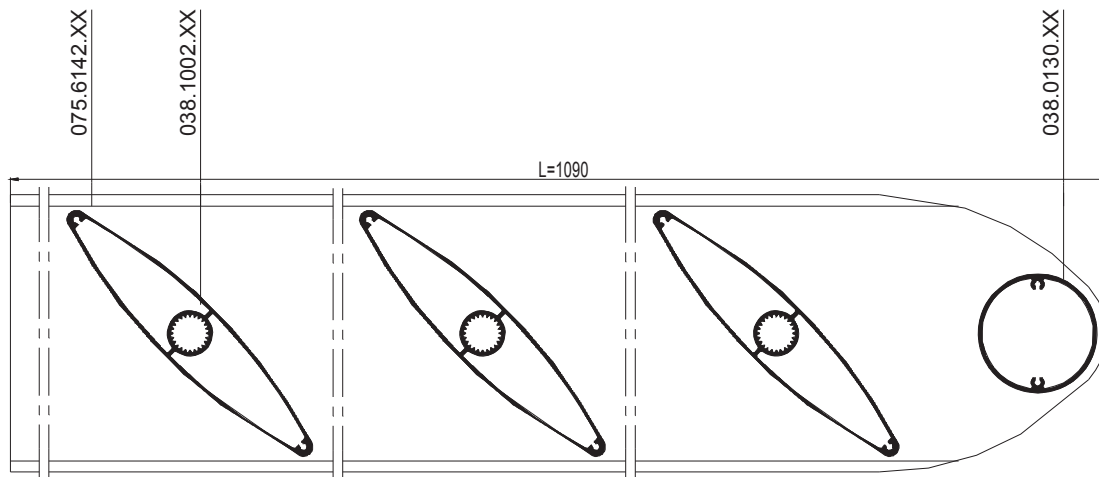

BS100-006001.dxf  
BS100-006001.dwg

7

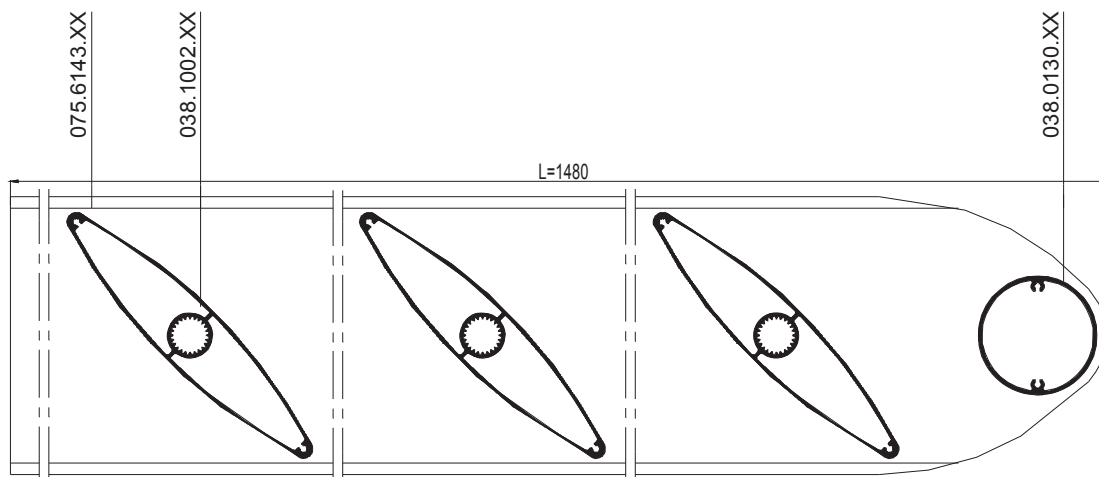

BS100-007001.dxf  
BS100-007001.dwg

BS 100 - 7



Moveable louvres with motor drive

General remark :

(\*) For recommendation on max. admissible sizes !  
Every typical situation and specific project has to be  
calculated / validated by an official structural engineer.

h= Depending on louvre dimension

10

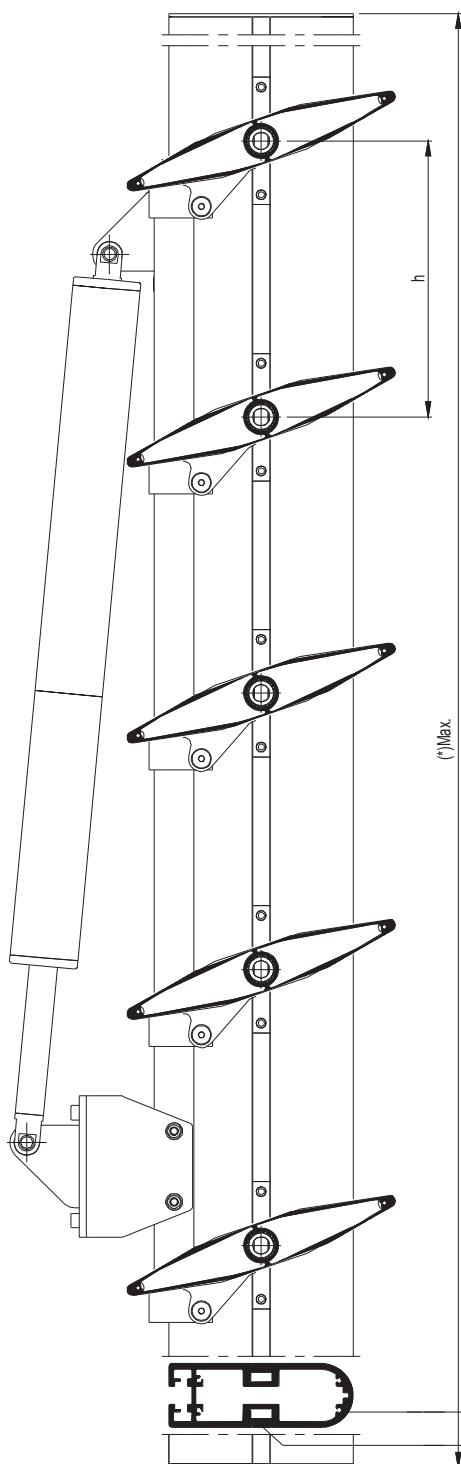
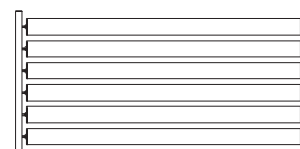

Louvre slope variabel

PR. NR.	Lw	h
038.1000.XX	120 mm	115 mm
038.1001.XX	140 mm	135 mm
038.1002.XX	180 mm	175 mm
038.1003.XX	200 mm	195 mm
038.1004.XX	250 mm	245 mm
038.1005.XX	300 mm	295 mm
038.1006.XX	400 mm	395 mm

Lw lamella width

h lamella distance

038.0100.XX

038.0120.XX

BS100-010001.dxf  
BS100-010001.dwg



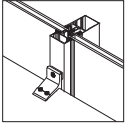

Fixed louvres in a vertical plane

General remark :

(\*) For recommendation on max. admissible sizes !  
Every typical situation and specific project has to be  
calculated / validated by an official structural engineer.

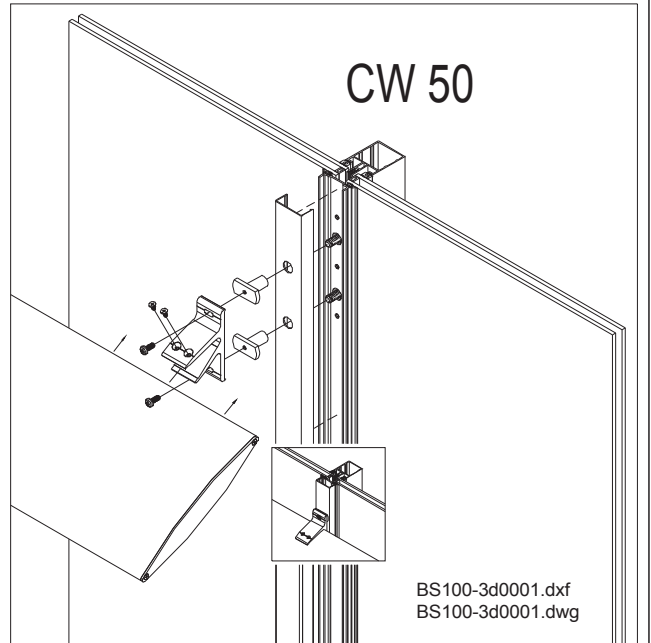

20

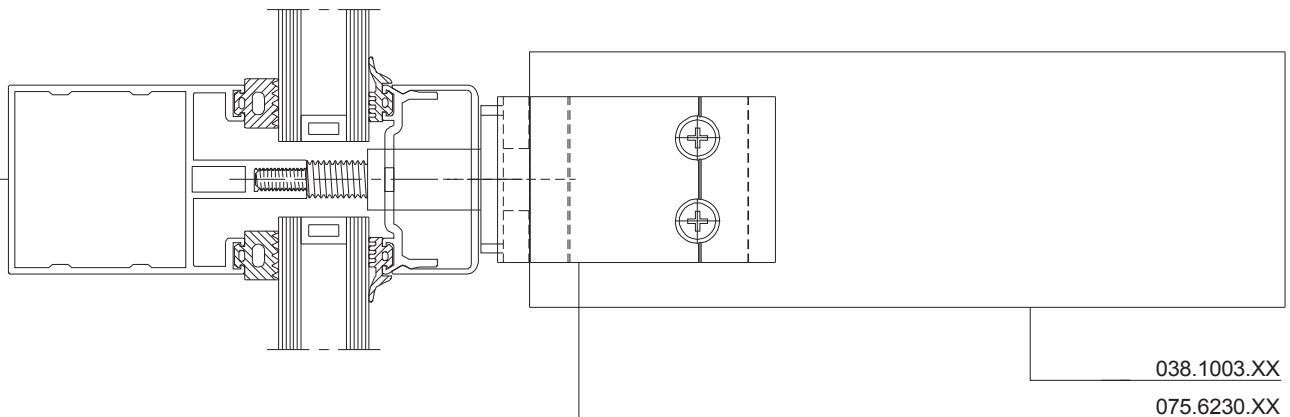

21 Louvre grip 0°

☞ ... .dxf  
☞ ... .dwg

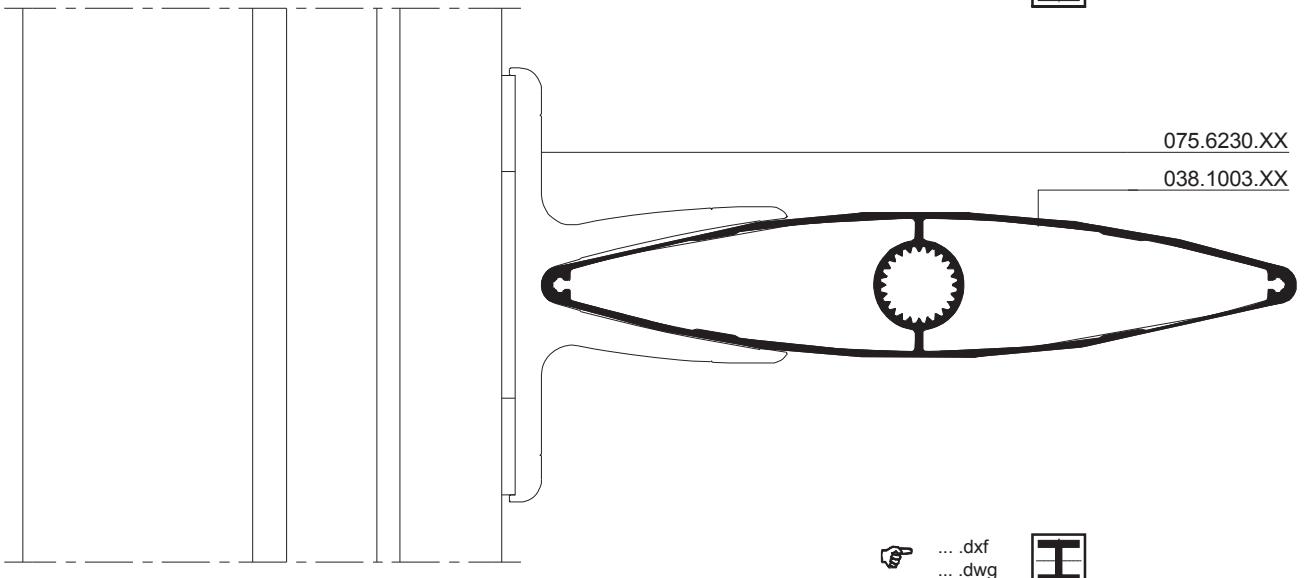

☞ ... .dxf  
☞ ... .dwg



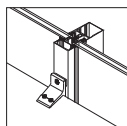

Fixed louvres in a vertical plane

## 038.1003.XX

$I_x = 17.128 \text{ cm}^4$

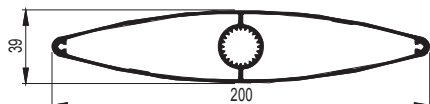

[20] BS100-020001.dxf  
BS100-020001.dwg

[21] BS100-021001.dxf  
BS100-021001.dwg

## 038.1004.XX

$I_x = 28.005 \text{ cm}^4$

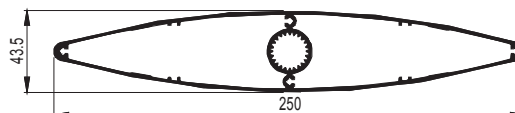

[20] BS100-020002.dxf  
BS100-020002.dwg

[21] BS100-021002.dxf  
BS100-021002.dwg

## 038.1005.XX

$I_x = 44.002 \text{ cm}^4$

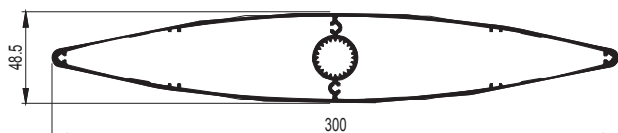

[20] BS100-020003.dxf  
BS100-020003.dwg

[21] BS100-021003.dxf  
BS100-021003.dwg

## 075.6230.XX

Louvre grip 0°



[21] BS100-021001.dxf  
BS100-021001.dwg

## 075.6231.XX

Louvre grip 0°



[21] BS100-021006.dxf  
BS100-021006.dwg

## 075.6232.XX

Louvre grip 0°



[21] BS100-021004.dxf  
BS100-021004.dwg

## 075.6233.XX

Louvre grip 0°

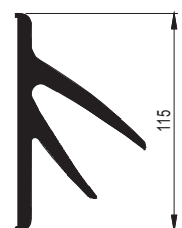

[21] BS100-021005.dxf  
BS100-021005.dwg



General remark :

For recommendation on max. admissible sizes !  
Every typical situation and specific project has to be  
calculated / validated by an official structural engineer.

Louvre slope 45°

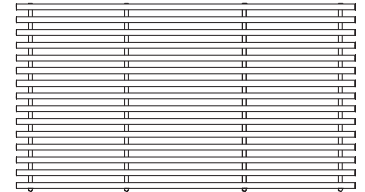

25 BS100-025001.dxf  
BS100-025001.dwg

26

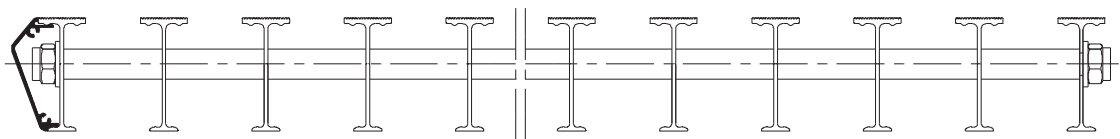

... .dxf  
... .dwg





038.0220.XX

$I_x = 7.118 \text{ cm}^4$

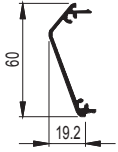

[26] BS100-026001.dxf  
BS100-026001.dwg

038.0230.XX

$I_x = 58.844 \text{ cm}^4$

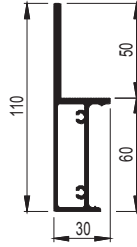

[26] BS100-026002.dxf  
BS100-026002.dwg



30 BS100-030001.dxf  
BS100-030001.dwg

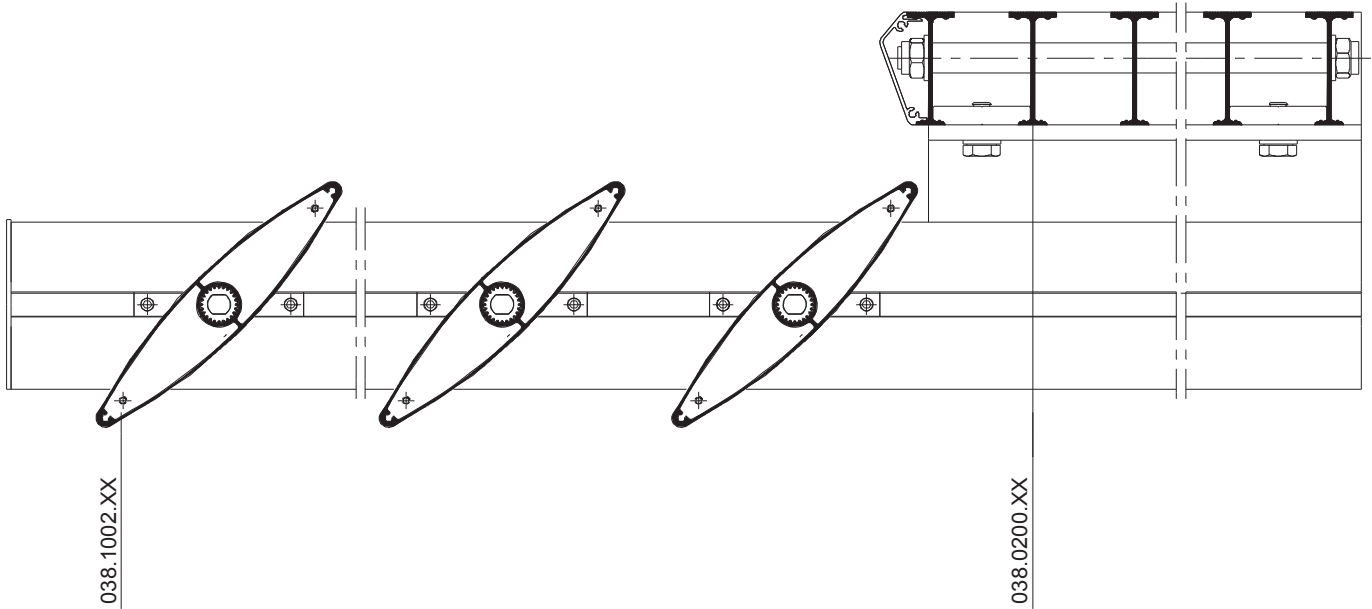

31 BS100-031001.dxf  
BS100-031001.dwg

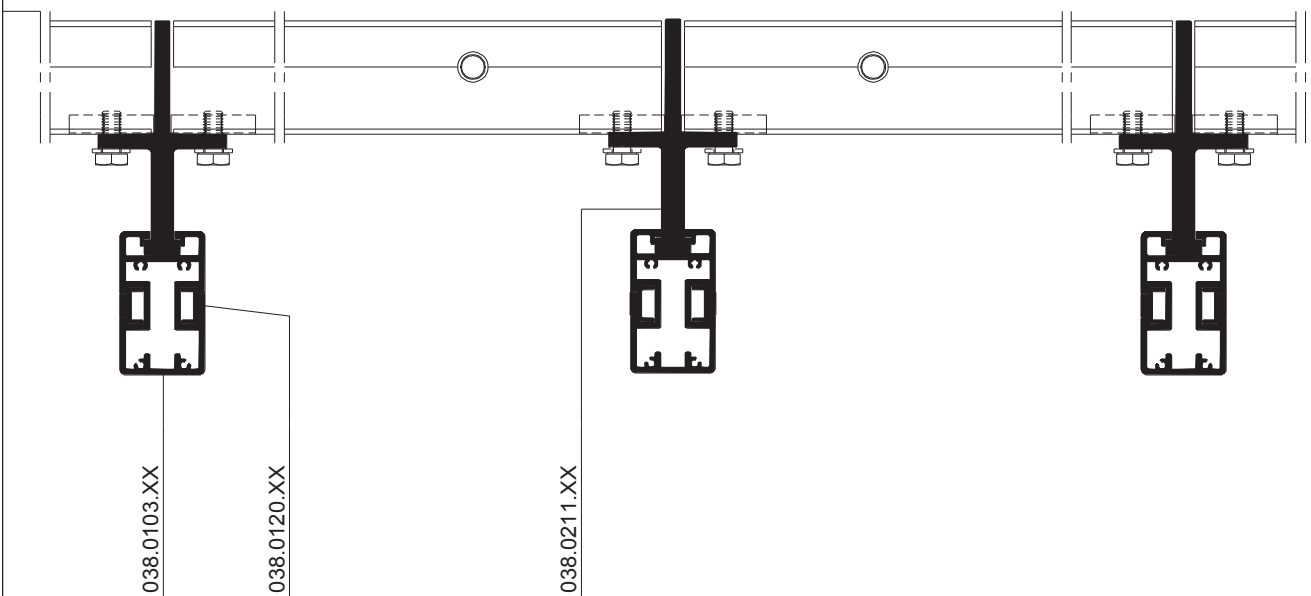

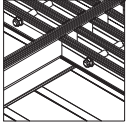

32 BS100-032001.dxf  
BS100-032001.dwg

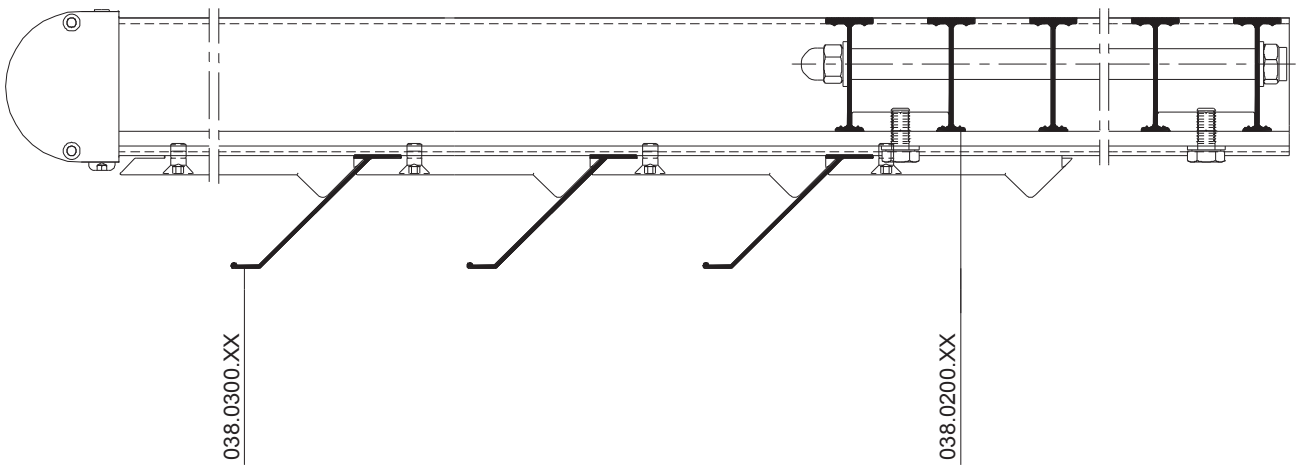

33 BS100-033001.dxf  
BS100-033001.dwg

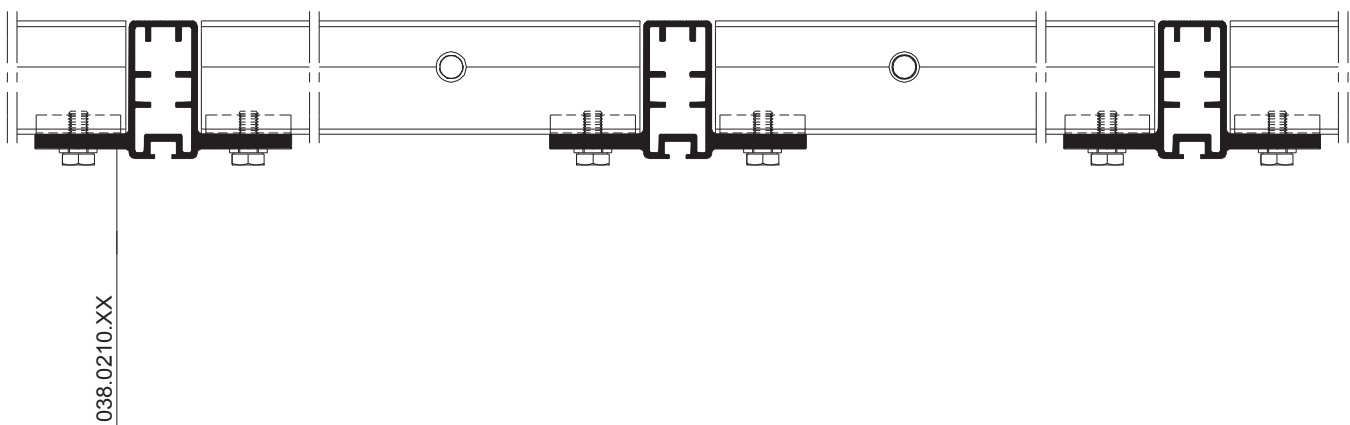



BS 100

---



## Connections with other systems

CW 50

BS 100 - CN002 ... CN003

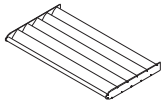

CW 50

CW 50

50 BS100-3d5001.dxf  
BS100-3d5001.dwg

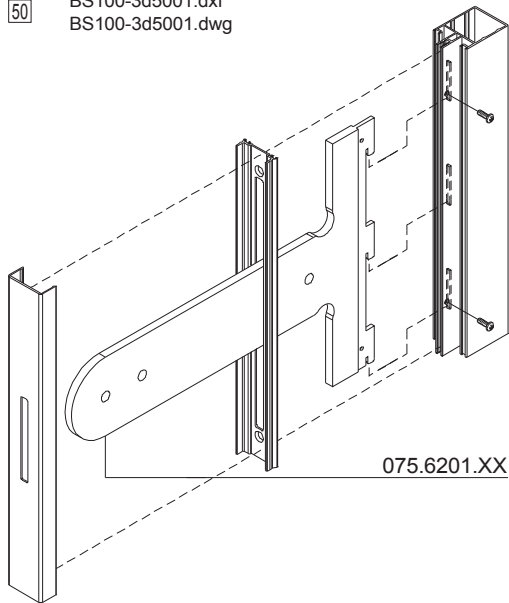

CW 50

50 BS100-3d5002.dxf  
BS100-3d5002.dwg

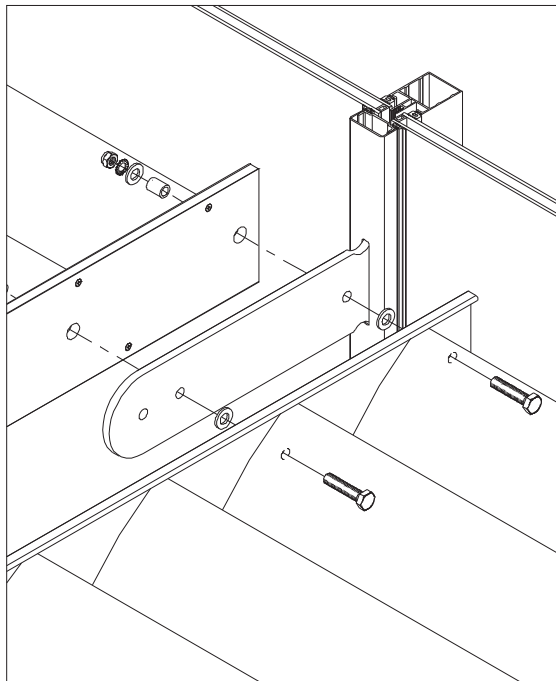

50 BS100-3d5003.dxf  
BS100-3d5003.dwg

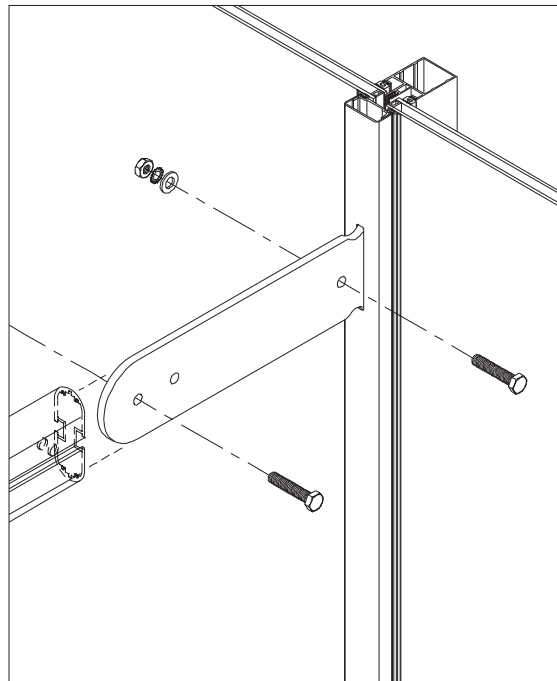



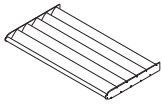

CW 50

CW 50

50 BS100-3d5004.dxf  
BS100-3d5004.dwg

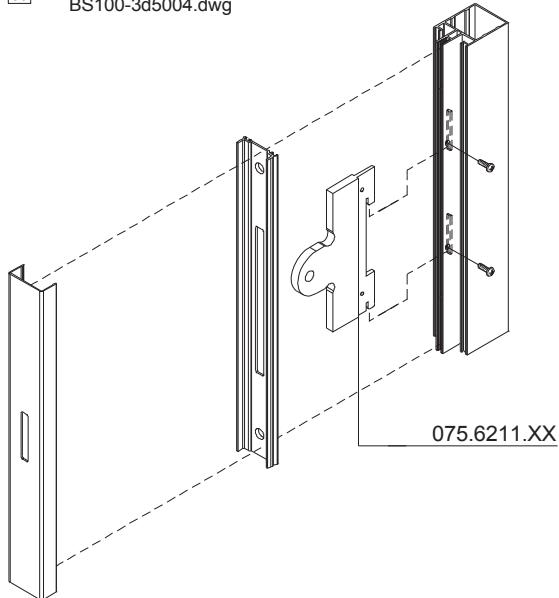

CW 50

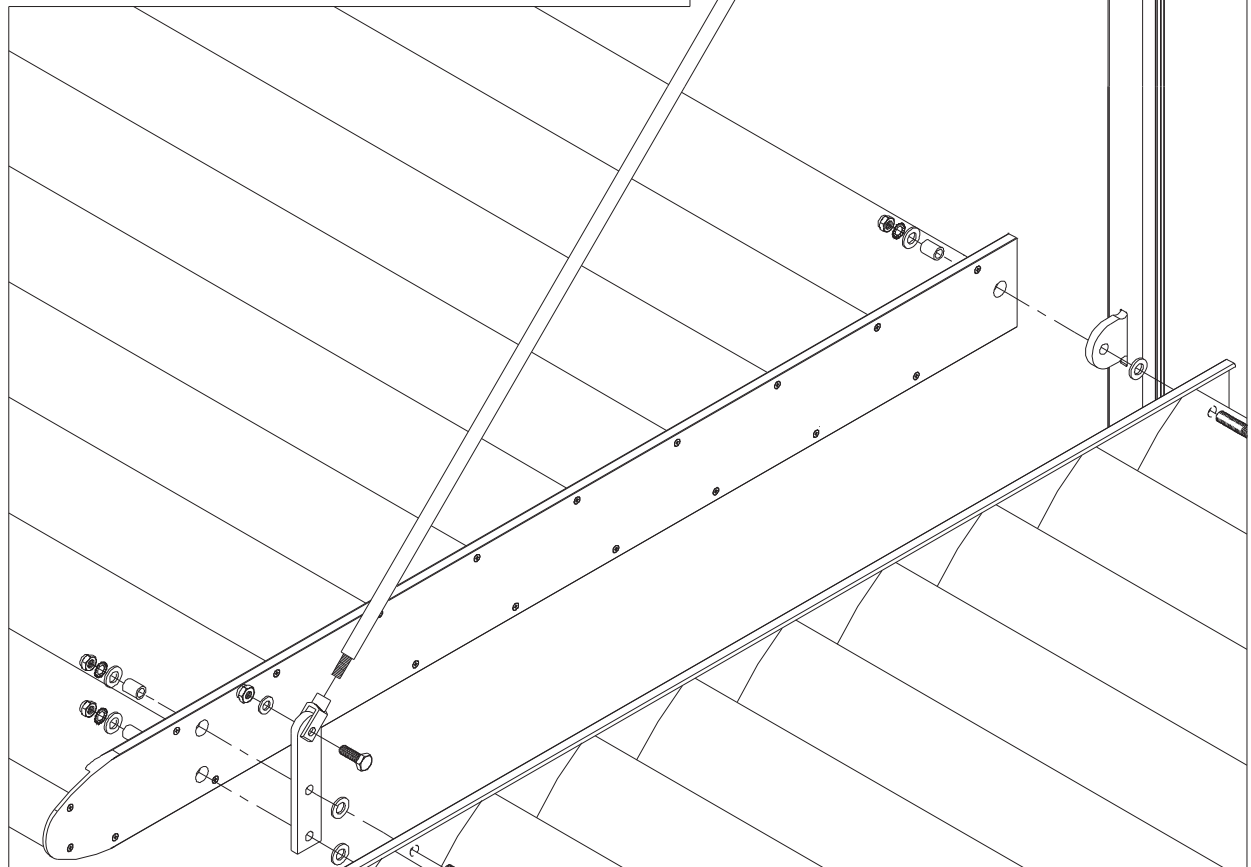

50 BS100-3d5005.dxf  
BS100-3d5005.dwg